

Country Christmas Mitered Corner Napkins

Finished dimensions: 16" x 16"
Featuring *Country Christmas Stripe* #2960-11



Bring Country Christmas to your dinner table with our simple mitered corner napkins.

MATERIAL NEEDED:

2 Dinner Napkins = ½ yard
4 Dinner Napkins = 1 yard

1. * Cut (1) square 18" x 18".
* *First Fold:* Fold the four raw edges ½" toward the wrong side of the fabric. Press.
* *Second Fold:* Fold the edges ½" toward the wrong side again. Press.

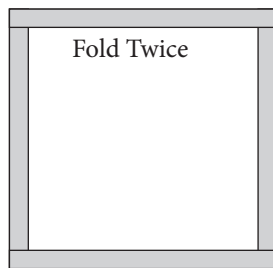

3. * Unfold the corner and trace the crease with a water erasable marker or fabric pencil.

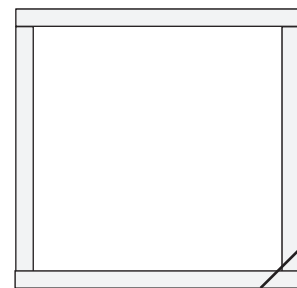

2. * Unfold the *Second Fold* at one corner.
* Following diagram, fold the corner into a triangle so that its two 'legs' measure 1". Finger press fold.

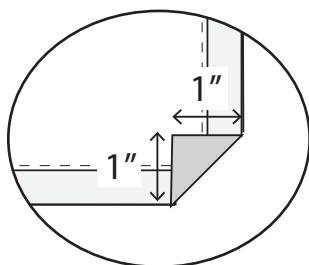

4. * Fold the corner over into a point, right sides together, making sure the ends of the drawn lines meet. Pin the corner into place.

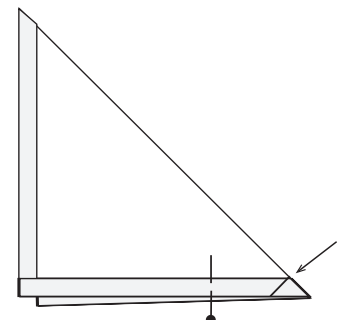

5. * Sew the two sides together along the traced line, backstitching at the beginning and end of the seam. Trim the tip of the corner off, leaving a $\frac{1}{8}$ " seam allowance. Finger press seam open.
- * Repeat steps 2 and 3 for the other three corners.

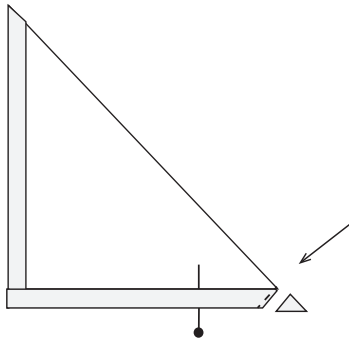

6. * Refold the *Second Fold*, inserting the corners into their neat mitered position as you do.
- * Push the tips of the corners out so they are pointy.
- * Press and pin down the *Second Fold*.

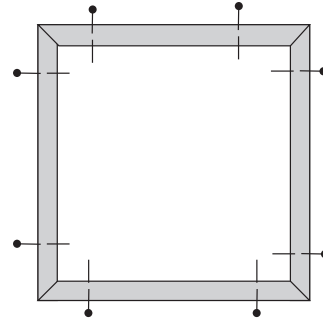

7. * Edge-stitch the fold around all four sides, backstitching at the beginning and end of the seam.
- * Your napkin is finished!
- * Now, repeat for all the remaining napkin squares and you have a set!

